

**ZEUS** HYDRATECH LTD  
*Global Suppliers of Premium Hydraulic Components*

Email: [sales@zeushydratech.com](mailto:sales@zeushydratech.com)  
Tel: +44(0)1172 130042

# HPVR-29 AXIAL PISTON PUMPS



The HPVR series of inline axial piston variable displacement pumps, are available in five displacements and three compact frame sizes.

These pumps feature medium-high working pressure capabilities that will meet most applications.

The output flow and pressure is controlled by a variety of control options, and can easily work in conjunction with external control components making them the perfect choice for almost any application.

The HPVR series pumps are available in both SAE and ISO mounting 2 bolt patterns. Porting is available in rear and side locations as well as thru-drive configurations.

TYPICAL PERFORMANCE SPECIFICATIONS			
VOLUMETRIC DISPLACEMENT	cu. In./rev.	3.97	
	ml/rev.	65	
PUMP DELIVERY @ 1750 RPM	GPM	29	
	LPM	109.8	
OPERATING PRESSURES	Intermittent*	PSI	4500
		BAR	310
	Continuous	PSI	4000
		BAR	275
Minimum**	PSI	200	
	BAR	14	
OPERATING SPEEDS	Maximum RPM	3000	
	Rated RPM	1750	
	Minimum RPM	500	
INPUT POWER @ 1750 RPM (Rated Flow and Pressure)	HP	82	
	kW	62	
CASE DRAIN FLOW @ Deadhead & Rated Pressure	GPM	1.9	
	LPM	7.2	
MOUNTING FLANGE	SAE Type	C 2-Bolt	
DRIVE SHAFT	Keyed Shaft SAE J744 C	1.25 in.	
	Spline Shaft SAE C	14 tooth	
SHIPPING WEIGHTS	REAR PORTS	lbs.	75
		kg	34
	SIDE PORTS	lbs.	90
		kg	41
	SIDE PORTS	lbs.	100
TANDEM	kg	45.5	

\* This pressure should not exceed 10% of the duty cycle and not exceed 6 consecutive seconds.

\*\* Pumps operating at less than 150 PSI (10 bar) may overheat and shorten pump life.

## CASE AND INLET PORT SPECIFICATIONS

SPEED rpm	Minimum Inlet Pressure					Maximum Case Pressure		
	Pressure Gauge			Absolute Pressure		psi	bar	
	psi	bar	in.-Hg	mm-Hg	psi	bar	psi	bar
1800	-3	-0.21	-6.12	-155.46	11.7	0.8	10	0.69
2050	-3	-0.21	-6.12	-155.46	11.7	0.81	7	0.48
2100	-2.45	-0.17	-4.99	-126.72	12.25	0.8	5	0.34
2200	-1.25	-0.09	-2.55	-64.8	13.45	0.9	5	0.34
2300	0	0	0	0	14.7	1	5	0.34
2400	1.31	0.09	2.66	67.88	16.01	1.1	5	0.34

## PRESSURE AND VOLUME ADJUSTMENT SENSITIVITY

Pressure Adjustment	Pressure Change / Turn	650 PSI	44.8 Bar
Volume Adjustment	Flow Change / Turn	2.8 GPM	10.6 LPM
	Maximum Torque	45 in.-lbs	5.1 Nm



# HPVR-29 AXIAL PISTON PUMPS

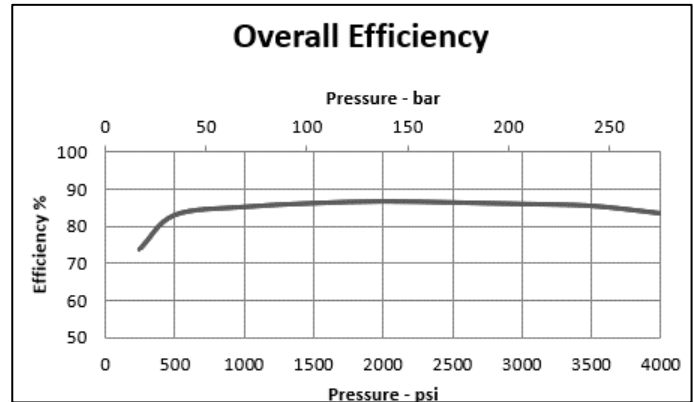
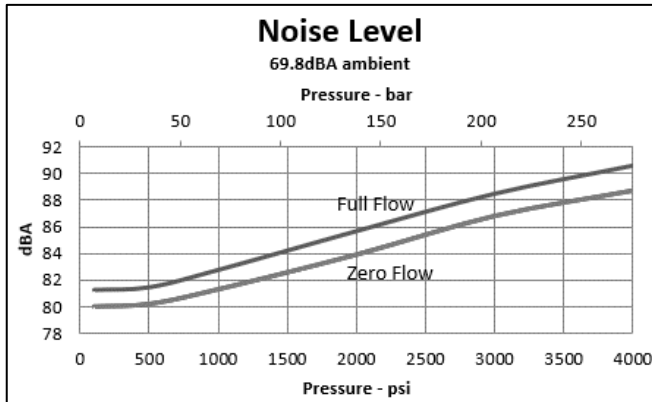
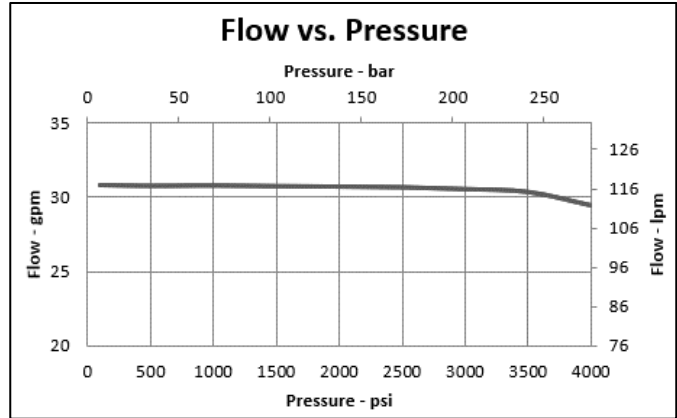
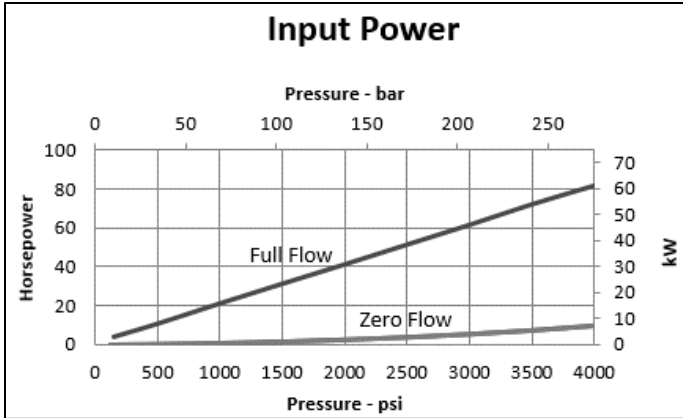

Data taken at 1800 RPM

# HPVR-29 AXIAL PISTON PUMPS



## Rear Port Dimension Data

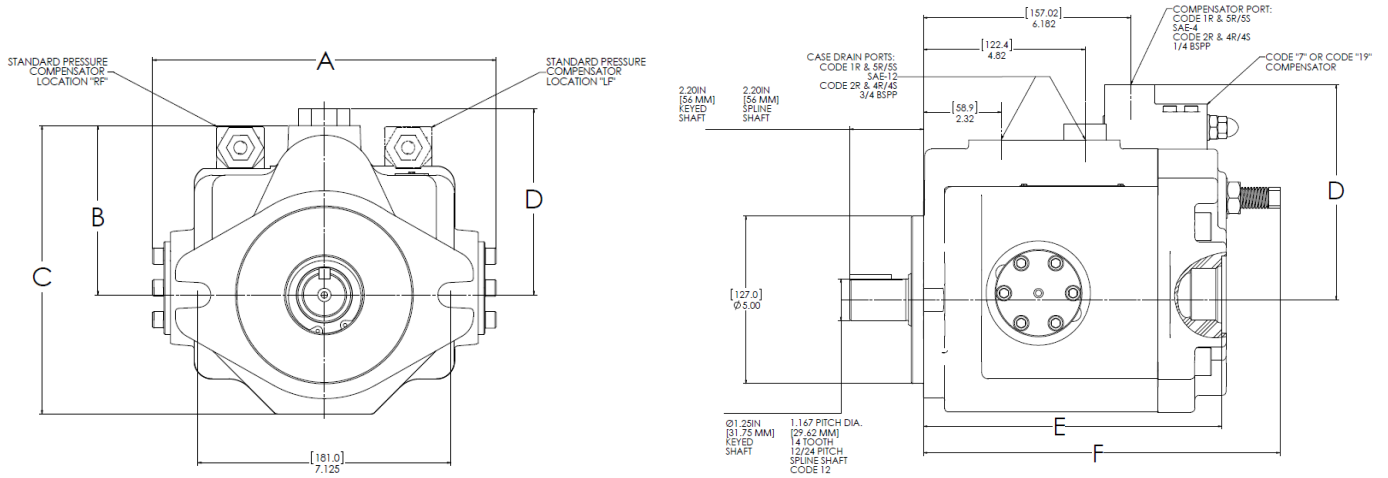

Dimensional Reference Data	Inch (mm)
<b>A</b>	9.66 (245.4)
<b>B</b>	4.76 (120.9)
<b>C</b>	8.11 (206)
<b>D (STD Pressure Compensator)</b>	5.24 (133)
<b>D (Code 7 Remote &amp; Code 19 Load Sense)</b>	6.41 (162.8)
<b>E</b>	8.9 (226)
<b>F</b>	10.64 (270.3)

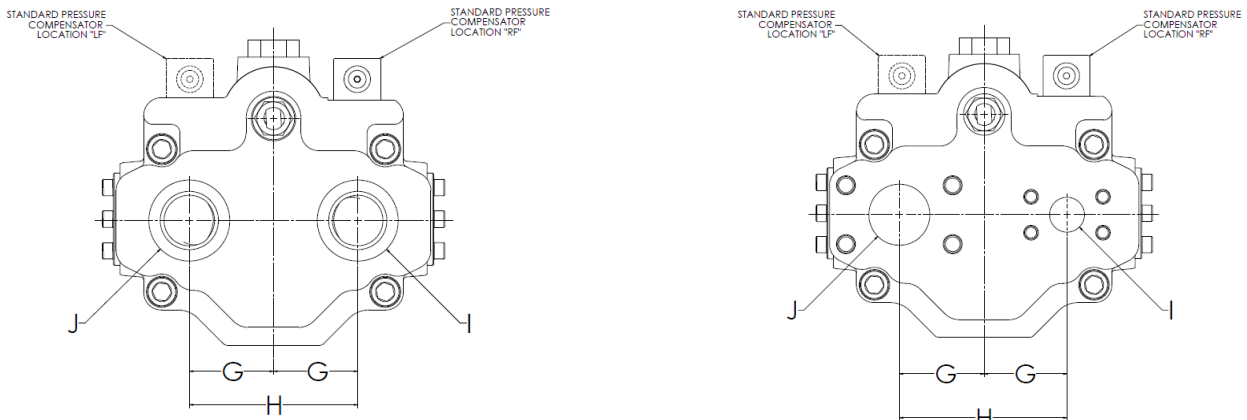

Dimensional Reference Data	Inch (mm)
<b>G</b>	2.375 (60.3)
<b>H</b>	4.75 (120.6)
<b>I Code 1R - Rear SAE Porting</b>	SAE-20
<b>I Code 2R- Rear BSPP Porting</b>	1-1/4 BSPP
<b>I Code 4R- Rear 4 Bolt Flange (Metric Threads)</b>	1 SF
<b>I Code 5R- Rear 4 Bolt Flange (UNC Threads)</b>	1 SF
<b>J Code 1R - Rear SAE Porting</b>	SAE-20
<b>J Code 2R- Rear BSPP Porting</b>	1-1/4 BSPP
<b>J Code 4R- Rear 4 Bolt Flange (Metric Threads)</b>	2 SF
<b>J Code 5R- Rear 4 Bolt Flange (UNC Threads)</b>	2 SF
<b>Note: REAR Port Flange are code 61, Both Pressure and Suction</b>	

# HPVR-29 AXIAL PISTON PUMPS

## Side Port Dimension Data

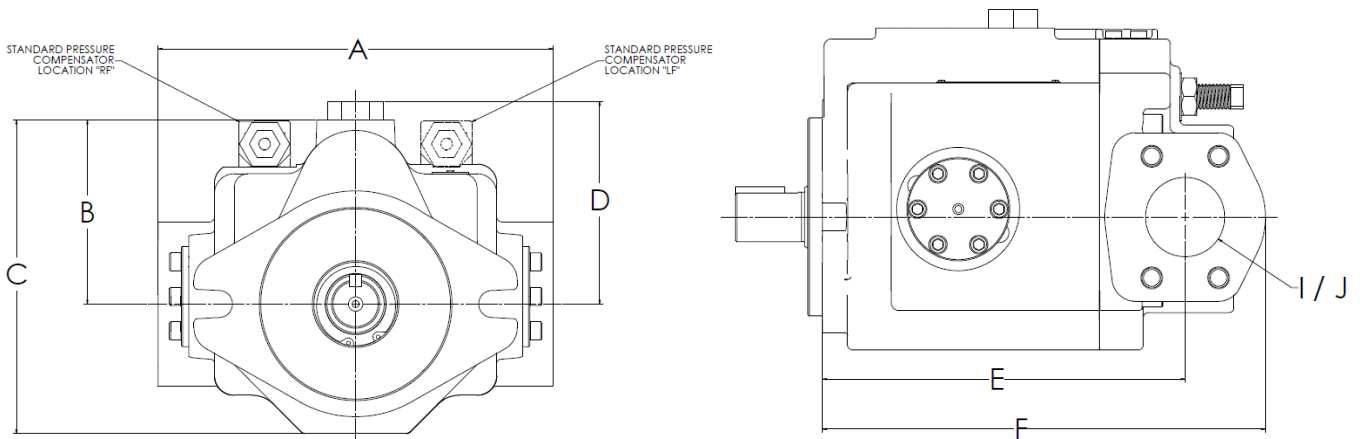

Dimensional Reference Data	Inch (mm)
<b>A</b>	10.24 (260.1)
<b>B</b>	4.76 (120.9)
<b>C</b>	8.11 (206)
<b>D</b> (STD Pressure Compensator)	5.24 (133)
<b>D</b> (Code 7 Remote & Code 19 Load Sense)	6.41 (162.8)
<b>D</b> (Code 26 Torque Limit)	9.52
<b>E</b>	9.16 (232.7)
<b>F</b>	11.12 (282.5)
<b>I</b> Code 4S- Side 4 Bolt Flange (Metric Threads)	1 SF
<b>I</b> Code 5S- Side 4 Bolt Flange (UNC Threads)	1 SF
<b>J</b> Code 4S- Side 4 Bolt Flange (Metric Threads)	2 SF
<b>J</b> Code 5S- Side 4 Bolt Flange (UNC Threads)	2 SF
Note: Suction Flange are code 61 and Pressure Flange are code 62	

# HPVR-29 AXIAL PISTON PUMPS

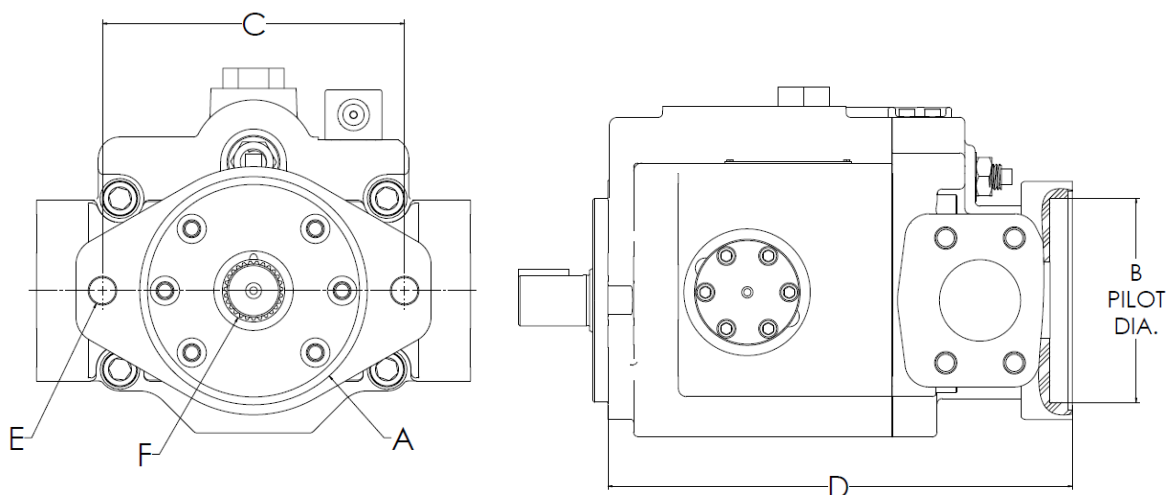

CODE	MOUNTING PAD	DIMENSIONS			Thread	30° Involute Internal Spline	Maximum H.P. Rating* (at 1750 RPM)	Maximum Torque Rating* (in-lbs)
		Inches (mm)						
	A	B	C	D	E	F		
21	SAE "A"	3.25 (82.6)	4.19 (106.4)	11.27 (86.26)	3/8-16 UNC	9 Tooth 16/32 Pitch 0.5625 Dia.	8.5	306
22	SAE "B"	4.00 (101.6)	5.75 (146.1)	11.43 (290.3)	1/2-13 UNC	13 Tooth 16/32 Pitch 0.8125 Dia.	28.1	1012
23	SAE "C"	5.00 (127.0)	7.13 (181.1)	11.55 (293.4)	5/8-11 UNC	14 Tooth 12/24 Pitch 1.1667 Dia.	43.8	1577
31	SAE "A"	3.25 (82.6)	4.19 (106.4)	11.27 (86.26)	3/8-16 UNC	13 Tooth 16/32 Pitch 0.8125 Dia.	28.1	1012
21D	SAE "A"	3.25 (82.6)	4.19 (106.4)	11.27 (86.26)	M10	9 Tooth 16/32 Pitch 0.5625 Dia.	8.5	306
22D	SAE "B"	4.00 (101.6)	5.75 (146.1)	11.43 (290.3)	M12	13 Tooth 16/32 Pitch 0.8125 Dia.	28.1	1012
23D	SAE "C"	5.00 (127.0)	7.13 (181.1)	11.55 (293.4)	M16	14 Tooth 12/24 Pitch 1.1667 Dia.	43.8	1577
31D	SAE "A"	3.25 (82.6)	4.19 (106.4)	11.27 (86.26)	M10	13 Tooth 16/32 Pitch 0.8125 Dia.	28.1	1012

\* This is the maximum horsepower or torque that can be transmitted through the shaft coupling to the rear pump



# HPVR-29 AXIAL PISTON PUMPS

HPVR -  -  -  -  -    - **B**

SELECT ONE    SELECT ONE    SELECT ONE    SELECT ONE    SELECT ONE    SELECT ONE    SELECT ONE    DESIGN LETTER

SIZE			
CODE	FLOW AT 1750 RPM	MAXIMUM PRESSURE	DISPLACEMENT
29B40	29 GPM	4000 PSI	$\frac{\text{in}^3}{\text{rev}}$ 3.78 $\frac{\text{cm}^3}{\text{rev}}$ 61.9

ROTATION	
CODE	DESCRIPTION
RF	CW ROTATION (STD)
LF	CCW ROTATION

SEALS	
CODE	DESCRIPTION
O	BUNA-N (STD)
P	VITON

PORT OPTIONS	
CODE	DESCRIPTION
1R	SAE C 2 BOLT MOUNTING FLANGE (STD) SAE O-RING THREAD CASE DRAIN REAR SAE O-RING THREAD PORTS
2R	SAE C 2 BOLT MOUNTING FLANGE BRITISH STD PIPE (BSPP) THREAD CASE DRAIN REAR BSPP THREAD PORTS
4R	SAE C 2 BOLT MOUNTING FLANGE BSPP THREAD CASE DRAIN REAR SAE 4 BOLT FLANGE (METRIC THREADS)
5R	SAE C 2 BOLT MOUNTING FLANGE SAE O-RING THREAD CASE DRAIN REAR SAE 4 BOLT FLANGE (UNC THREADS)
4S	SAE C 2 BOLT MOUNTING FLANGE BSPP THREAD CASE DRAIN SIDE SAE 4 BOLT FLANGE (METRIC THREADS)
5S	SAE C 2 BOLT MOUNTING FLANGE SAE O-RING THREAD CASE DRAIN SIDE SAE 4 BOLT FLANGE (UNC THREADS)

See Dimensional Pages for Port Size and Code Type

CONTROL OPTIONS	
CODE	DESCRIPTION
OMIT	PRESSURE COMPENSATOR (STD)
7	REMOTE COMPENSATOR
19	LOAD SENSING COMPENSATOR

TANDEM	
CODE	DESCRIPTION
OMIT	NO TANDEM OPTION (STD)
21	SAE "A" FLANGE PUMP MOUNT (UNC THREADS) SAE A SPLINE SHAFT COUPLING
22	SAE "B" FLANGE PUMP MOUNT (UNC THREADS) SAE B SPLINE SHAFT COUPLING
23	SAE "C" FLANGE PUMP MOUNT (UNC THREADS) SAE C SPLINE SHAFT COUPLING
31	SAE "A" FLANGE PUMP MOUNT (UNC THREADS) SAE B SPLINE SHAFT COUPLING
21D	SAE "A" FLANGE PUMP MOUNT (METRIC THREADS) SAE A SPLINE SHAFT COUPLING
22D	SAE "B" FLANGE PUMP MOUNT (METRIC THREADS) SAE B SPLINE SHAFT COUPLING
23D	SAE "C" FLANGE PUMP MOUNT (METRIC THREADS) SAE C SPLINE SHAFT COUPLING
31D	SAE "A" FLANGE PUMP MOUNT (METRIC THREADS) SAE B SPLINE SHAFT COUPLING

SHAFT	
CODE	DESCRIPTION
OMIT	STRAIGHT KEY (STD) SAE J744 C 1.25inch SHAFT
12	FRONT MALE SPLINE SAE C: 14 TOOTH 16/32 Pitch